



**Building Your Dream**

## **Building Materials Catalogue**





**BUILDING TRUST.  
SHAPING THE FUTURE...**



### COMPANY PROFILE

The Emel Group is one of Nigeria's leading business conglomerates with a major presence across diverse sectors including Consumer Products, Corporate Services and Infrastructure. For over four decades, the Group has made a significant contribution to the country's economy and inspired the trust of millions of Nigerians as a provider of quality goods at an affordable price. What began in 1966 as a humble, family-run trading enterprise has today grown into a professional powerhouse with over 400 employees, led by a highly qualified and globally experienced senior management team.

The Emel Group's headquarters are situated in Lagos, the commercial capital of Nigeria and supported by solid infrastructure including two manufacturing units and several warehouses. The Group also has operations in China, Hong-Kong and India.

At the heart of the Group's businesses are the core values of trust, respect, recognition, security & growth. These values are the pillars on which the Emel brand and reputation have been built. Driven by its vision, "To enrich quality of life by delivering customers' needs today and tomorrow", Emel has introduced many successful products to the Nigerian marketplace.



### BUILDING MATERIALS

The Emel Group markets a wide array of Building Materials products which cater to both dealers and end-users such as architects, developers, builders and construction companies.

### GLOBAL PARTNERS

In order to provide the Nigerian marketplace with world-class products and services, Emel has formed strategic alliances with international companies including Tilcor (New Zealand), Formet (Turkey), Everest (India), FG Glass (India), Agro Fiber (Thailand) and Krost Shelving (South Africa).

The Group plans to further expand its portfolio in the near future by introducing a range of specialty products from Vietnam, Egypt, Malaysia and Italy.

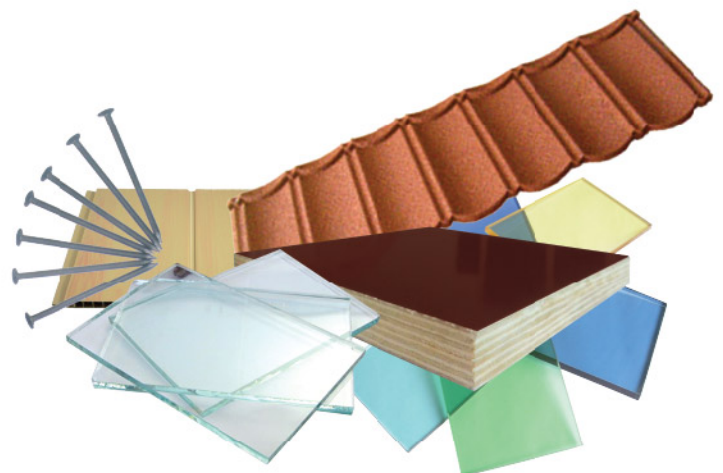

### BRANDS



# CONTENTS

## Doors

- 02 Security Doors
- 04 MDF / Wooden Doors
- 05 Armoured / Turkey Doors
- 06 PVC / Toilet Doors
- 07 Door Skins

## Ceilings & Flooring

- 08 PVC Panel
- 09 Gypsum Board
- 09 Gypsum Ceiling
- 10 Mineral Fibre Ceiling
- 10 Ceiling Grids
- 11 PVC & Vinyl Sheet Flooring

## Glass & Mirrors

- 12 Aluminium Mirror
- 12 Silver Mirror
- 13 Bronze Tinted / Reflective Glass
- 13 Clear Float / Sheet Glass
- 14 Dark Blue/Green Tinted/ Reflective Glass
- 14 Other Tinted/Reflective Glass

## Wood Panels

- 15 Melamine MDF / Chip Board
- 16 Commercial Plywood
- 16 WBP Film Faced Marine Plywood
- 17 Hardboard

## Cement Boards & Wall Panels

- 18 Fibre Cement Boards
- 19 Solid Wall Panels

## Architectural Products

- 20 Roofing Tiles

## Global Partners

- 22 Tilcor Roofing Tiles from New Zealand
- 23 FG Glass, Architectural Glass Solutions from India
- 24 Formet, Security Armed Doors from Turkey
- 24 Everest, Cement Boards from India
- 25 Agro Fiber, Hardboard from Thailand
- 26 Krost Shelving, Shelving & Racking Solutions from South Africa



## SECURITY DOORS

DOORS

- A - High Quality Steel Plate
- B - U Type Reinforced Steel
- C - Stainless Steel Edge
- D - Strengthened Burglarproof Door Frame
- E - Steel Bracket for Anchor Bolts
- F - Wood Architrave
- G - Top and Bottom Lock Bolts
- H - Wood Veneer on HDF Board
- I - Wide Angle Peephole
- K - High Quality Security Lock
- L - Stainless Steel Hinges
- M - Sound-proof & Dust-proof Seal
- N - Reinforced Anti-pry Tab
- O - Sound-proof Gaskets



*Stainless Steel Edge Treatment*



*Steel Edge Treatment*



*Solid Wood Edge Treatment*



**EMSD001**



**EMSD002**



**EMSD003**



**EMSD004**



**EMSD005**



**EMSD006**



**EMSD007**



**EMSD008**



**EMSD009**



**EMSD010**



**EMSD011**



**EMSD012**



**EMSD013**



**EMSD014**



**EMSD015**



**EMSD016**



**EMSD017**



**EMSD018**



**EMSD019**



**EMSD020**

## COLOR

### Powder Coat Color Reference

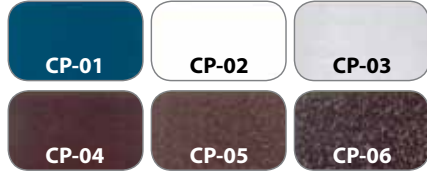

### Heat Transfer Color Reference

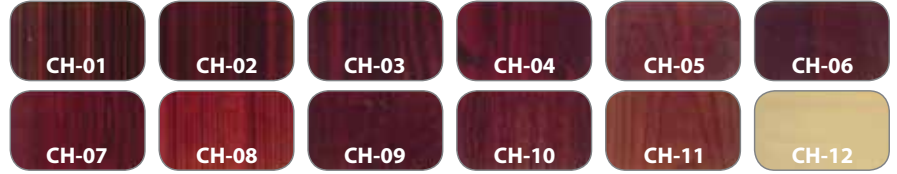

## PEEPHOLE



## HANDLE

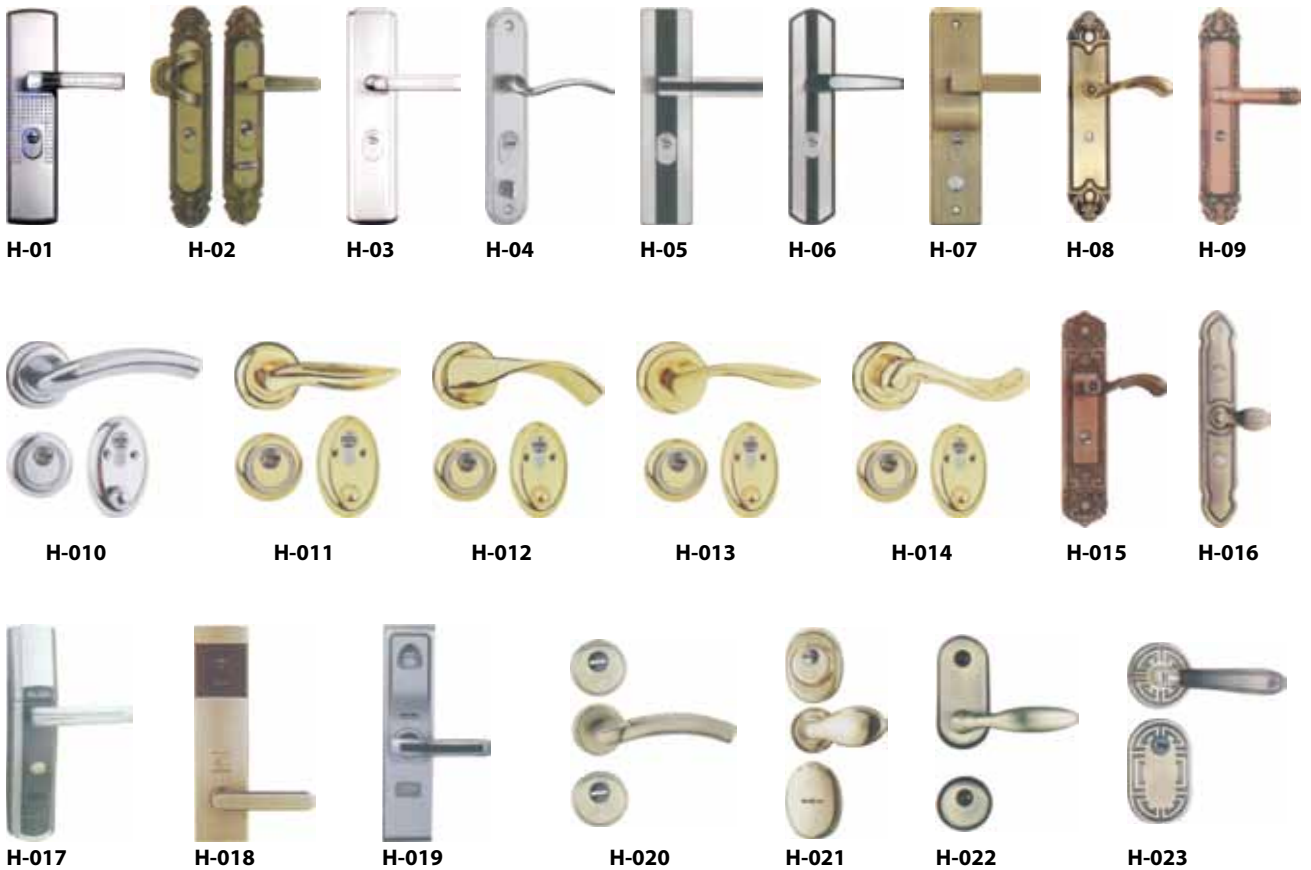

## MDF/WOODEN DOORS

DOORS



EMMD001



EMMD002



EMMD003



EMMD004



EMMD005



EMMD006



EMMD007



EMMD008



EMMD009



EMMD010



EMMD011



EMMD012

### COLOR



White Ash



White Oak



Maple Wood



Tak Wood



Sapele



Thai Teak



Red Pear



Iron Peach



Black Walnut

### SUPPORTING COMPONENTS

#### Door Frame



#### Handle





## ARMOURED/TURKEY DOORS



EMMD001



EMMD001



EMMD001



EMMD001



EMMD001



EMMD001



EMMD001



EMMD001



EMMD001



EMMD001



EMMD001



EMMD001



EMMD001



EMMD001



EMMD001



EMMD001



EMMD001



EMMD001

## SUPPORTING COMPONENTS



## PVC/ TOILET DOORS

### LAMINATED



EPD-001



EPD-002



EPD-003



EPD-004



EPD-005



EPD-006



EPD-007



EPD-008



EPD-009



EPD-010



EPD-011



EPD-012

### FOLDING



EMPF001



EMPF002



EMPF003



EMPF004



EMPF005



EMPF006



EMPF007



EMPF008



EMPF009



EMPF010



EMPF011



EMPF012



EMPF013



EMPF014



## DOOR SKINS



EDS-001



EDS-002



EDS-003



EDS-004



EDS-005



EDS-006



EDS-007



EDS-008



EDS-009



EDS-010



EDS-011



EDS-012



EDS-013



EDS-014



EDS-015



EDS-016



EDS-017



EDS-018



EDS-019



EDS-020

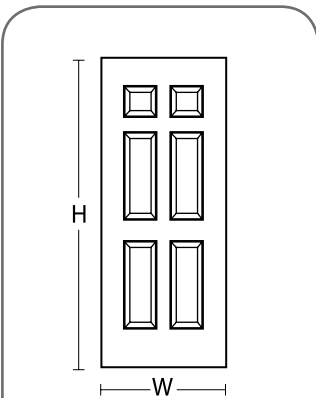

### SPECIFICATION

Width(W) : 860/920/1020mm

Height(H) : 2150mm

Thickness : 3.2 ± 0.1mm



EDS-021



EDS-022

### COLOR OPTIONS



Cassia Siamea  
(Tech)



Black Walnut  
(Tech)



Black Cherry  
(Tech)



Red Oak  
(Tech)



Natural Fraxinus  
Mandshurica



Natural Teak



Sapele  
(Tech)



Teak  
(Tech)



White-washed  
Oak (Tech)



Natural Black Walnut



Natural Sapele



Natural Red Oak



# CEILING & FLOORING

## PVC PANELS

CEILING & FLOORING



EMP001



EMP002



EMP003



EMP004



EMP005



EMP006



EMP007



EMP008



EMP009



EMP010



EMP011



EMP012



EMP013



EMP014



EMP015



EMP016



EMP017



EMP018



EMP019



EMP020



EMP021



EMP022



EMP023



EMP024



EMP025



EMP026



EMP027



EMP028



EMP029



EMP030

\* Subject to availability of designs





## GYPSUM BOARD

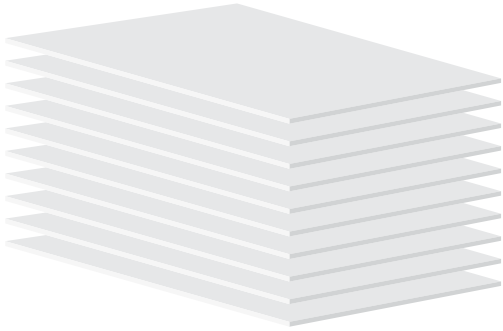

CEILING & FLOORING

### SIZE

- 1200 X 2500 X 12 mm
- 1200 X 2700 X 12 mm
- 1200 X 3000 X 12 mm
- 1200 X 2500 X 10 mm
- 1200 X 2700 X 10 mm
- 1200 X 3000 X 10 mm

### Type of Edge:

TAPERED	<input type="checkbox"/>
SQUARE	<input type="checkbox"/>

## GYPSUM CEILING

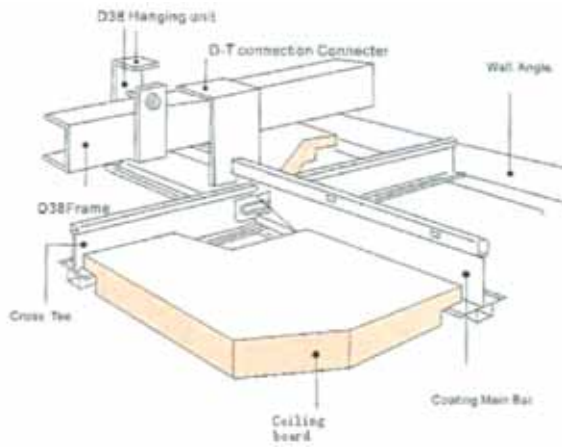

EMG01



EMG02



EMG03



EMG04



EMG05



EMG06



EMG07



EMG08



EMG09



EMG10





## MINERAL FIBRE CEILINGS

CEILINGS & FLOORING



M01



M02



M03

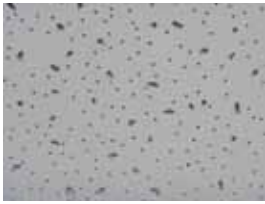

M04



M05



M06



M07



M08



M09

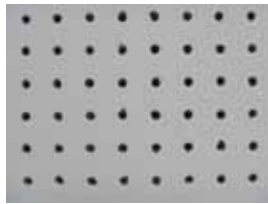

M10



M11



M12

## CEILING GRIDS

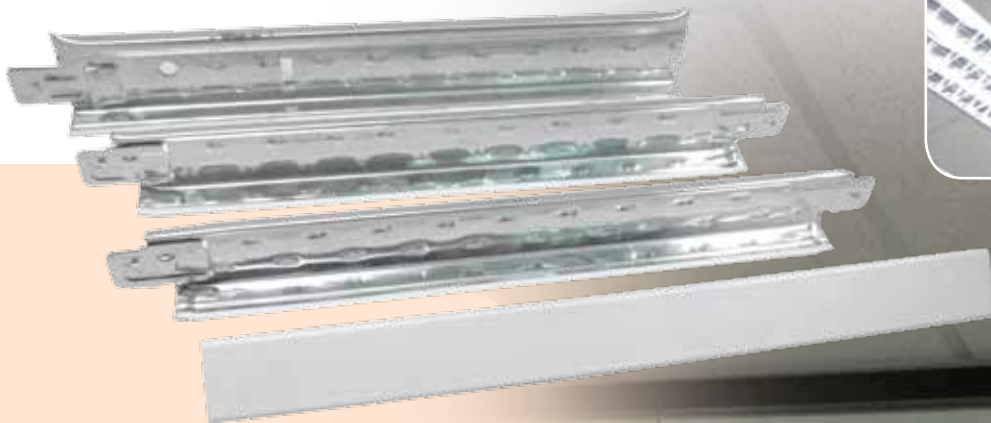



# CEILING & FLOORING

## PVC & VINYL SHEET FLOORING

### SIZE

0.35mm X 72" X 30M / ROLL

1.2mm X 72" X 30M / ROLL



CEILING & FLOORING



F802



F1702



F3403



F5915



F7205



F7221



F7608



F7805



F8001

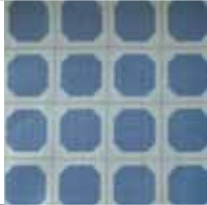

F9125

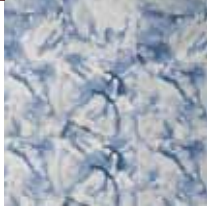

F10001



F10004

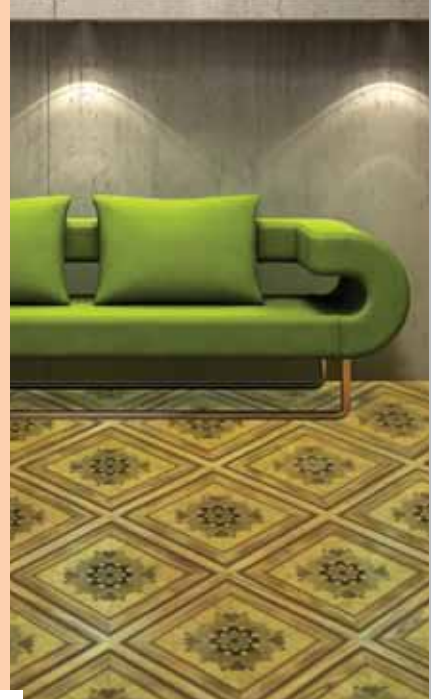





## MIRRORS



GLASS & MIRRORS

### ALUMINUM MIRROR

#### SHEET MIRROR

Thickness	Size
1.8-2mm	610 x 914 mm
2.7-3mm	406 x 1220 mm 1220 x 1830 mm

#### FLOAT MIRROR

Thickness	Size
4mm	1220 x 2440 mm 1830 x 2440 mm
5mm	1220 x 2440 mm 1830 x 2440 mm

### SILVER MIRROR

Thickness : 4mm, 5mm

Size : 2134 x 3300 mm  
1830 x 2440 mm  
1220 x 1830 mm





## GLASS

### BRONZE TINTED/REFLECTIVE GLASS



#### ADVANTAGES

- High transmission rate for visible light
- Energy saving on air-conditioning
- Provide soft & warm light indoor

#### THICKNESS

Bronze Tinted Glass: 4, 5, 6, 8, 10mm  
Bronze Reflective Glass: 4, 5mm



### CLEAR GLASS

#### ADVANTAGES

- Smooth and flat surface
- Excellent optical performance
- Stable chemical properties
- Resistant to acid, alkaline and corrosion
- Flexible size specifications, minimizing cutting loss

#### APPLICATION

- Window and doors, furniture, mirrors, automobiles
- Exterior facade for commercial and residential buildings
- Interior glass partitions

#### THICKNESS

4, 5, 6, 8, 10, 12, 15, 19mm





### DARK BLUE/ GREEN TINTED/REFLECTIVE GLASS

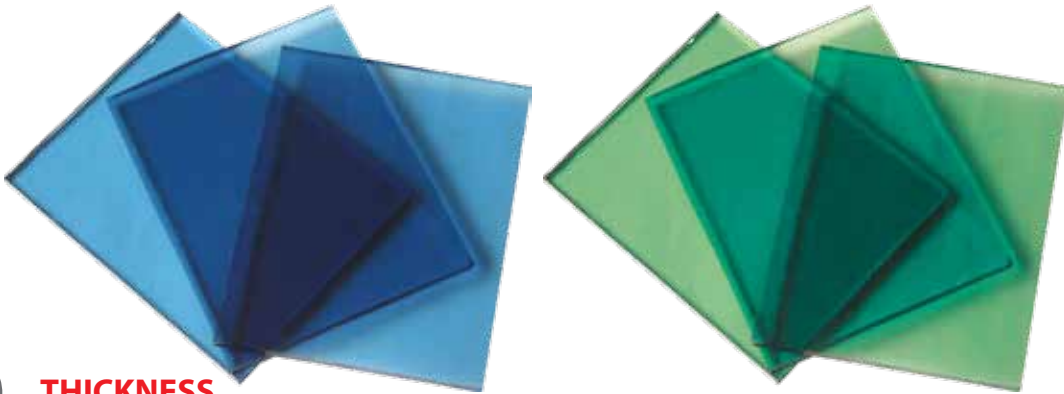

**THICKNESS**  
4, 5, 6, 8, 10mm

### OTHER TINTED/REFLECTIVE GLASS

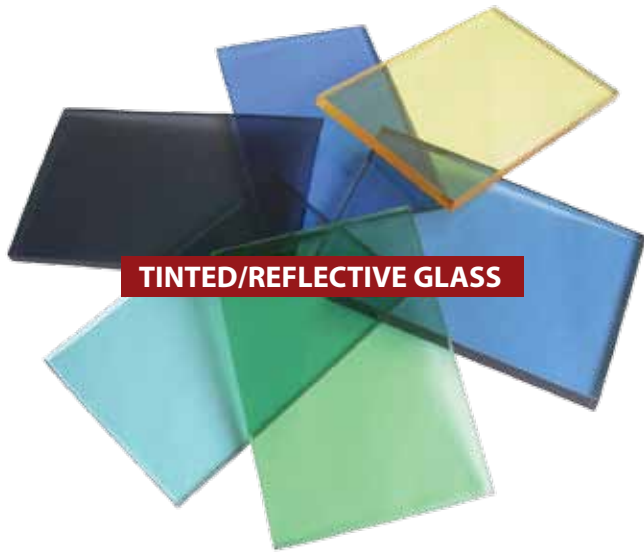

**THICKNESS**  
4, 5, 6, 8, 10mm



GLASS & MIRRORS





# WOOD PANELS

## MELAMINE MDF BOARD/CHIP BOARD



### MELAMINE MDF BOARD

Size: 1220 x 2440 x 3-18 mm



### MELAMINE CHIP BOARD

Size: 1220 x 2440 x 3-18 mm

WOOD PANELS

### COLOR OPTIONS

White	Teak	Sapele	Orange	Oak	Maple
Light Green	Green	Grey	Cherry	Bright Yellow	Blue
Black	Black Walnut	Beech	Mahogany	Bright Red	





# WOOD PANELS

## COMMERCIAL PLYWOOD

Size : 1220mm x 2440mm (4'x8')

Thickness : 2.2mm - 25mm

Glue : MR, WBP

Core : Poplar / Hardwood

Face / Back : Okoume / Birch / Bintangor / White Poplar / Cedar

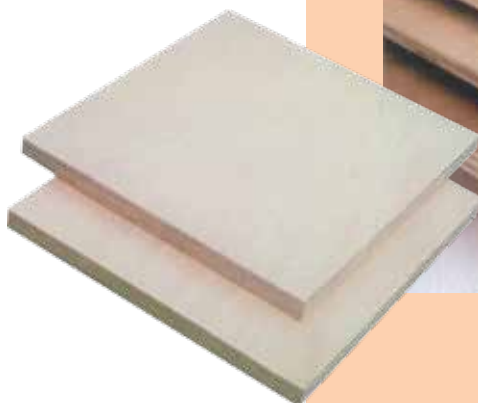

## WBP FILM FACED MARINE PLYWOOD

Size : 1220 x 2440 mm

Thickness : 6 - 18mm

Core : Hardwood, Poplar or Combi

Face / Back : Brown / Black Film

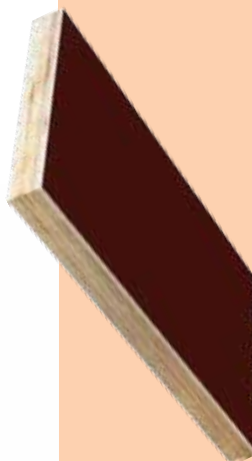

WOOD PANELS





## HARDBOARD



WOOD  
PANELS

### Advantages

- Good Mechanical Strength
- Ease of Finishing (e.g. Lacquering & Veneering)
- Good Flexibility
- Large Sizes
- Easy to Cut into Sizes

### Application

- Use in Furniture (backs and drawer bottoms)
- Building Woodwork (doors, facings, partitions, ceilings)
- Manufacturing of packaging material
- Automotive industry (door panels, car finishing elements)

### Types

- Plain hardboards
- Perforated hardboards

### Standard Dimension

1220 mm x 2440 mm

### Thickness

2.0, 2.5, 3.0 mm

### HIGH QUALITY TEXTURE



## FIBRE CEMENT BOARDS

### MULTIPURPOSE CEMENT BOARDS

#### Areas of Application

- False ceiling
- Internal walls - half height/full height
- Internal wall lining
- Eaves and soffit lining
- Pre-fabricated shelter - internal/external walls

#### Finishing Choices



### HEAVY DUTY CEMENT BOARDS

#### Areas of Application

- Internal wall - High traffic/Impact prone areas residential/Commercial/Industrial
- Wet area lining - kitchen, bathroom
- Commercial flooring
- Rain screening/substrate for render
- External wall cladding/bracing non load bearing/load bearing walls/residential/commercial/industrial/cladding walls in warehouses/factories
- Pre-fabricated shelter - internal/external walls

#### Finishing Choices

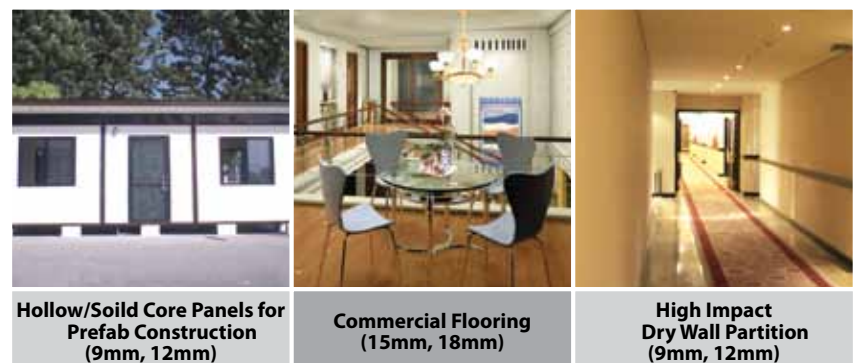



## SOLID WALL PANELS

### DESIGNER CEMENT BOARDS

#### Areas of Application

- Internal walls - half height/full height
- Internal walls - lining/paneling
- Ceilings

#### Available Range



- Remarks:
- Cascade, Lake & Hill and Polygon are only available in white pre-primer finish
  - Brick is available in above indicative finish, ready to install for exterior applications



## SOLID WALL PANELS

#### Advantages

- Speed - 20 times faster
- Space - 3 to 5% additional
- Light weight - 90% lighter than brick/block wall
- Fire rating > 2 hours

#### Areas of Application

- Internal walls - residential/commercial/industrial
- External walls - cladding walls in warehouses/factories
- Pre-fabricated shelter - internal/external walls

#### Superior Attributes



Quick Installation



Strength



Lightweight

#### Finishing Choices



Texture Coating



Veneer



Wallpaper



Paint





## ROOFING TILES



### Classical



<b>Tile Size</b>	1400mm X 420mm
<b>Installed Exposure</b>	1350mm X 370mm
<b>Tiles / Square Meter</b>	2 Piece / M2
<b>Weight / Tile</b>	3 Kgs
<b>Installed Weight</b>	6 Kgs / M2
<b>Quantity in 20ft Container</b>	8000 Pieces / 4000 M2

### Traditional



<b>Tile Size</b>	1400mm X 420mm
<b>Installed Exposure</b>	1350mm X 370mm
<b>Tiles / Square Meter</b>	2 Piece / M2
<b>Weight / Tile</b>	3 Kgs
<b>Installed Weight</b>	6 Kgs / M2
<b>Quantity in 20ft Container</b>	8000 Pieces / 4000 M2

### Light-weighted

- As light as 6kg/m2, approximately 1/8 of that of clay tile and cement tile

### Environment Friendly

- Recyclable

### Sturdy & Durable

- One of the most economical roofing solutions
- Waterproof, good thermal insulation, corrosion resistant

### Windproof

- Suitable for all kinds of roofs, including high buildings

### Easy Installation & Maintenance

- Material is flexible and easy to resize, approximately 2 pieces for each square meter

### Makuti-grained



<b>Tile Size</b>	1300mm X 420mm
<b>Installed Exposure</b>	1250mm X 370mm
<b>Tiles / Square Meter</b>	2.16 Piece / M2
<b>Weight / Tile</b>	2.8 Kgs
<b>Installed Weight</b>	6 Kgs / M2
<b>Quantity in 20ft Container</b>	8640 Pieces / 4000 M2

# ARCHITECTURAL PRODUCTS



Light-weighted  
**Windproof**  
*Environment friendly*  
**Sturdy & Durable**

## COLOR OPTIONS



EMEL 1003  
**Red**



EMEL 1007  
**Brick**



EMEL 1009  
**Clay**



EMEL 1011  
**Terracotta**



EMEL 1012  
**Burgandy**



EMEL 2005  
**Cream**



EMEL 3002  
**Blue Sky**



EMEL 3003  
**Black**



EMEL 3006  
**Arctic Blue**



EMEL 2008  
**Teak**



EMEL 2013  
**Coffee Brown**



EMEL 2017  
**Thatch**



EMEL 4002  
**Charcoal**



EMEL 4006  
**Light Gray**



EMEL 4007  
**Black & White**



EMEL 3008  
**Dark Green**



EMEL 3011  
**Forest Green**



EMEL 3012  
**Navy Blue**

## ACCESSORIES

Side Flashing

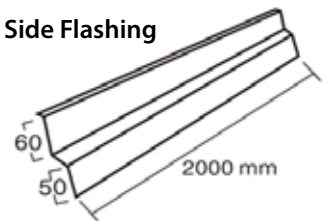

Valely Tray

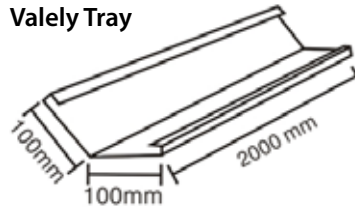

Flat Board

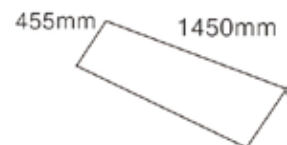

Box Barge Cover

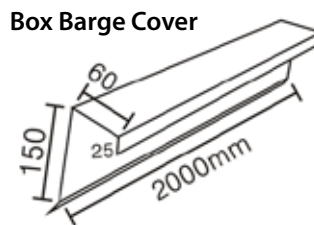

Square Ridge Cap

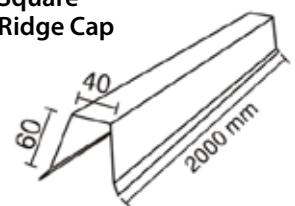





# GLOBAL PARTNERS

## GLOBAL PARTNERS

Emel has formed strategic alliances with international companies including Tilcor (New Zealand), Formet (Turkey), Everest (India), FG Glass (India), Agro Fiber (Thailand) and Krost Shelving (South Africa).



New Zealand



India



Turkey



India



Thailand



South Africa

### CERTIFICATION





# GLOBAL PARTNERS



## New Zealand

The Emel Group is the Authorised Distributor of Tilcor in Nigeria. TILCOR is an innovative manufacturer and supplier of affordable, lightweight stone-coated and satin-finish roof systems in Zincalume protective steel.

that has been in operation since 1989. Since this time it has built an enviable reputation internationally for excellence in product design, quality manufacturing and competitiveness.

The Tilcor range caters for all types of construction from residential to light-commercial and public works, and comprises of three distinct profiles: **Shake®**, **Tudor®** and **Royal®**. All Tilcor products are manufactured to ISO 9001 accreditation within the company's New Zealand factory

Tilcor roofing systems offer exceptional strength and durability in the harshest of climates. They are water, fire and earthquake resistant; can withstand hurricane-force winds and are backed by a Tilcor warranty.



### Shake®

For a textured finish with wood-grain appearance of traditional shake. Deep ribbed profiles add dimension and shadow lines to create visual contrast.



### Tudor®

For a more traditional or solid enduring look of a clay tile, yet without the weight, the Tudor range is one of our most popular profiles.



### Royal®

For a low profile shingle appearance, yet with the strength and durability of a press metal tile, the Royal profile is the ultimate product.

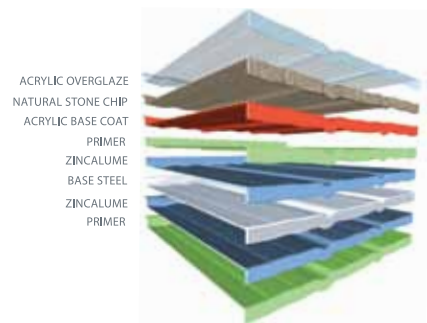

SPECIFICATIONS		TUDOR	ROYAL	SHAKE
LENGTH OF COVER	1265mm			
WIDTH OF COVER	368mm			
TILES / m <sup>2</sup>	2.15 / m <sup>2</sup>			
WEIGHT / m <sup>2</sup>	6.4 KGS			
MINIMUM ROOF PITCH	12.5 DEGREES			
	15 DEGREES			



# GLOBAL PARTNERS

India



The Emel Group represents FG Glass, India's leading architectural glass manufacturer, in Nigeria. FG Glass designs, produces and delivers architectural glass products and solutions for all building requirements supplying to major real-estate developers, curtain wall and structural glazing fabricators and building construction companies. The company has successfully completed projects in India and in twenty countries globally including in Bangladesh, Sri Lanka, Mauritius, Seychelles, UAE, US, Tanzania, Uganda, Kenya and Nigeria amongst others.

FG Glass offers a wide range of world-class products and services to deliver complete glass solutions for all building requirements. These include: Glass Solution and Architectural Glazing Solutions.

<h2>Glass Solutions</h2>		<p>Green Building Solutions</p>
	<p><b>glasshield</b> HEAT-STRENGTHENED</p>	
<p><b>glasshield</b> TOUGHENED FLOAT</p>		
		<p><b>enamelite</b> CERAMIC FRIT GLASS</p>
		<p><b>climacool</b> INSULATED GLASS</p>
<h2>Architectural Glazing Solutions</h2>		<p><b>curveshield</b> BEND-TOUGHENED GLASS</p>
<p>Spider Frameless Glazing</p>		
<p>Curtain Walling</p>		<p><b>lamisecure</b> LAMINATED GLASS</p>
		<p><b>blaze</b> FIRE-RATED GLASS</p>
<p>Skylights &amp; Canopy</p>		
<p>Stainless Steel Railing Systems &amp; Balustrades</p>	<p>Structural Glazing (Stick Glazing / Semi-Unitized / Unitized)</p>	
		<p><b>bulletshield</b> BULLET-RESISTANT GLASS</p>
<p>Aluminium Composite Panels Cladding</p>		<p><b>mirage</b> ELECTRONIC SWITCHABLE GLASS</p>
	<p>Insulated Windows &amp; Glazings, Sound Proof Windows &amp; Glazings, Sliding Windows / Pivoted Windows / Openable Windows</p>	





# GLOBAL PARTNERS



## Turkey

To further strengthen its position in the security doors segment, the Emel Group has formed an alliance with Formet Steel Door Company. Formet is a leading global steel door manufacturer with 15 years of manufacturing experience. The company has a comprehensive range of products which are produced according to international and ISO-9001 quality standards.



## India

The Emel Group represents Everest, a one-stop-shop world-class building solutions provider, in Nigeria. Founded in 1934, Everest has continuously introduced innovative and modern building products with a promise of strength, speed and safety. The company's extensive product portfolio includes roofing, ceilings, walls, flooring, cladding, doors and pre-engineered steel buildings which are used extensively by the industrial, commercial and residential sectors.

The Everest brand of products are produced to international and ISO: 9000 quality standards through its state of the art manufacturing facilities spread over 5 locations in India. After successfully catering to the Indian market, Everest has widened its horizons in the international arena. With consistent exports to Europe, Africa, Australia, Asia and now Africa, Everest is all set to scale new heights and establish a strong foundation in the global market.

- Roofing
- Walls
- Ceiling
- Flooring
- Cladding
- Doors
- Steel Buildings





# GLOBAL PARTNERS

## Thailand



The Emel Group has tied up with Agro Fiber Company Limited (AGF), a leading Hardboard (HB) manufacturer based in Thailand. AGF is committed to maximizing customer satisfaction and delivering the best quality products by using **best quality Eucalyptus** plywood from the company's own Farm Tree. AGF has a strong customer base both locally and internationally and regularly exports to Africa, South Asia, and the Middle East.



AGF's 2.5mm **superior grade hardboard** is widely available in Nigeria through Emel's network. This fine quality and durable hardboard is used for **construction, household & interior jobs**.

### Physical Product

- Toughness
- High intensity
- Smooth surface



### Green & Non Toxic

- Natural bonding: use only naturally occurring wood glues (lignin) to bond fibers.
- Formaldehyde: content < 0.02ppm v/v





# GLOBAL PARTNERS



## South Africa

### Krost Shelving

Emel offers a range of Racking & Shelving solutions from Krost shelving, a household name in South Africa. Krost shelving has been designing and manufacturing Steel Racking, Shelving and Mezzanine Floors since 1948. The company was one of the first racking companies in Africa to have been awarded the South African Bureau of Standards (SABS) mark for excellence of quality standards; it is also an ISO 9001-2008 certified company.



### Racking

- **Selective Pallet & Selective Storage**
- Efficient, economical use of space
- Direct access to stored items
- Easy to install and adjust.



### Rivet Shelving

- **Durable Shelving, ideal for use in warehouses, offices & retail stores.**



### Mezzanine Floors

- **Add extra floors pace within the shell of an existing building. They can be used as storage, fabrication or packing areas as well as offices.**
- Quick, clean and easy to install
- Can be disassembled / re-assembled to another location
- Can be increased or decreased in size to suit needs







A series of horizontal dashed lines spanning the width of the page, providing a template for writing or drawing.

Recognition  
**trust** Security  
building trust. shaping the future...  
**R e s p e c t**  
Growth



**Building Materials**